

Hydrogen-ready Power Protection

Low carbon UPS solution for clean energy

*Chloride protects the power that
decarbonizes the world*



About us



“ Chloride® today is a global company based in France dedicated to the design, manufacturing and service of electrical equipment to ensure safety of people and assets in the industrial environment.
Our strategy is focused on:

- **Energy transition** support for our customers with new applications, carbon footprint reduction, and technology innovation.
- **Circular economy** approach with systems upgrade and life extension programs and NPD accounting for recyclable materials.
- **Long-term sustainability** by investing in the new battery and UPS technology development.

”

Henri Chignier, CEO

Operating in the market for over 75 years, Chloride® has carried out numerous projects in conventional and renewable energy applications including photovoltaic and concentrated solar power plant, onshore & offshore wind farms, hydrogen and carbon capture and storage units.



Global Headquarters

Lyon - France

~400 employees

~50 authorized partners

~12 international offices

Applications

Green Hydrogen

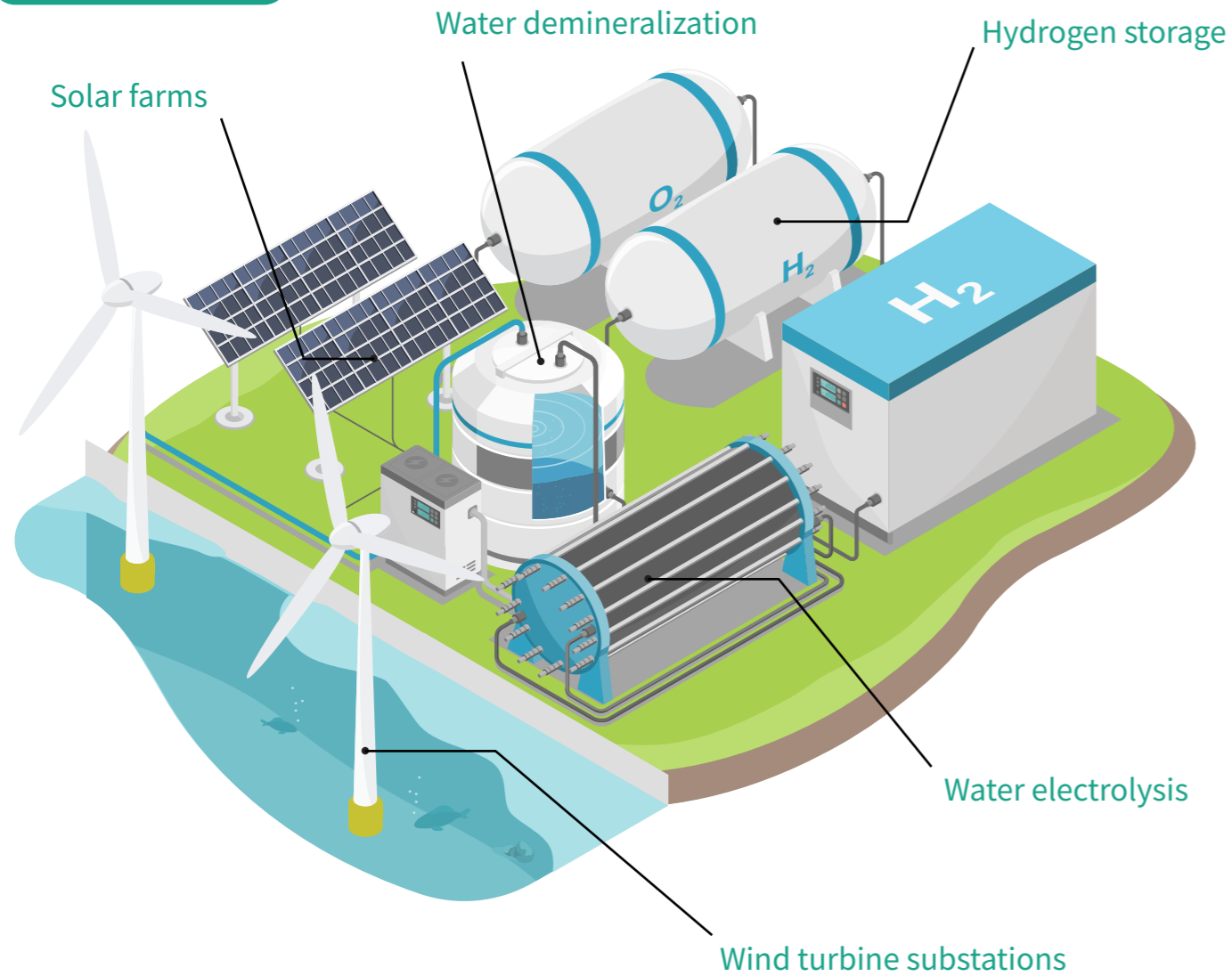

Green hydrogen refers to hydrogen gas that is produced using renewable energy sources, such as wind, solar, or hydroelectric power, through a process called electrolysis. During electrolysis, water molecules are split into hydrogen and oxygen using electricity.

Chloride® solutions guarantee a permanent power supply to the most sensitive equipment throughout the value chain such as Hydrogen leak detection systems, electrolyzer control and command systems, water treatment, remote monitoring systems, transformer substations for offshore wind turbines, SCADA systems, control of hydrogen transport in pipelines, compressor stations. Chloride® solutions can operate in both conventional and ATEX environments.

Blue Hydrogen

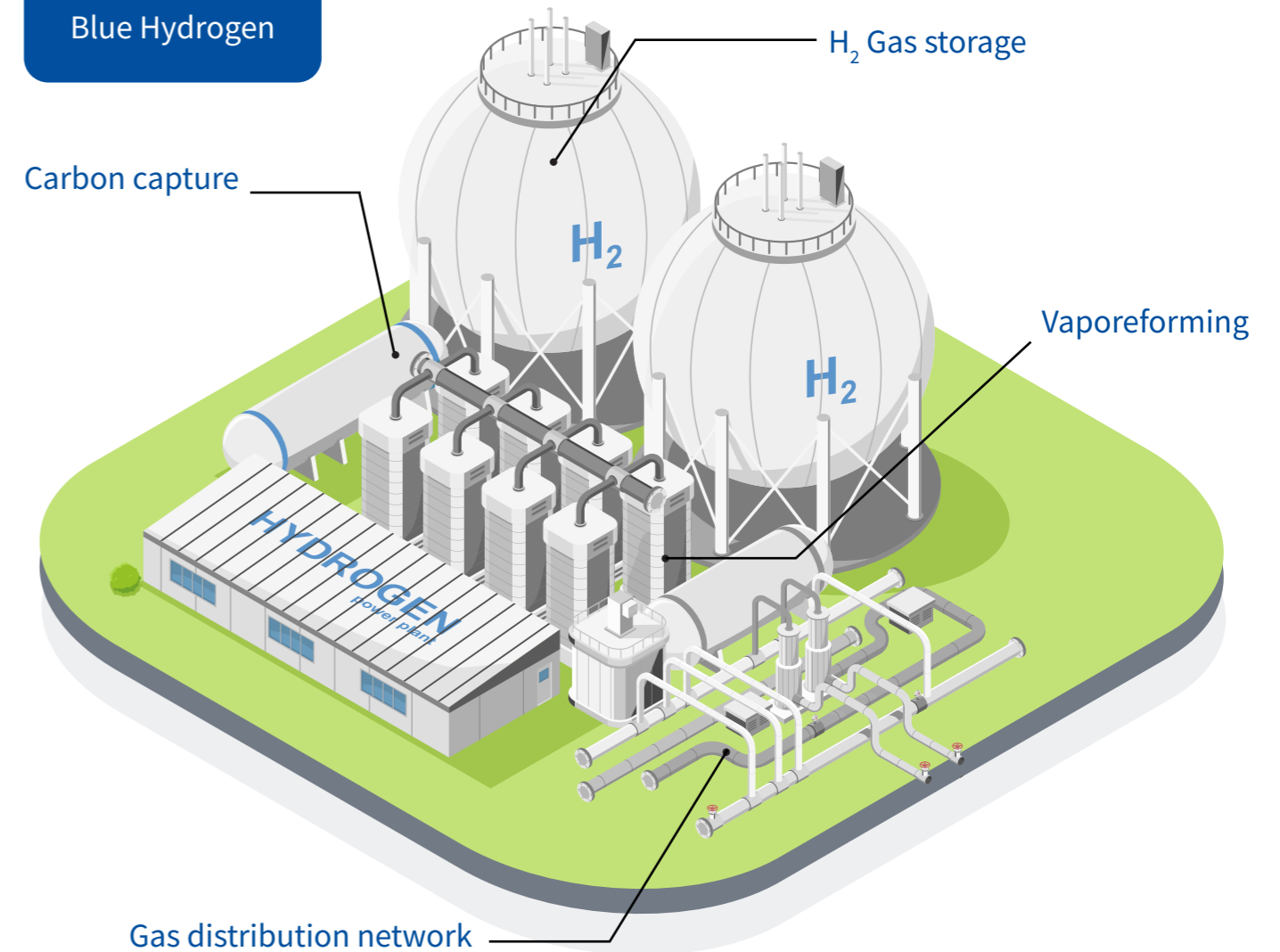

Blue hydrogen is a term used to describe hydrogen gas produced through a process that combines natural gas with carbon capture and storage (CCS) technology. In this process, methane, which is the primary component of natural gas, is separated into hydrogen and carbon dioxide. The carbon dioxide is then captured and stored, preventing it from being released into the atmosphere. Blue hydrogen production aims to provide a more environmentally friendly alternative to traditional Grey hydrogen.

Chloride® solutions provide continuous power to the most sensitive equipment throughout the value chain, such as hydrogen leak detection systems, steam reforming control systems, remote monitoring systems, carbon capture systems, SCADA systems, carbon storage systems, compressor stations, hydrogen pipeline transport control. Chloride solutions can operate in both conventional and ATEX environments.

Chloride® reinvents the traditional UPS solution with lower carbon footprint

The carbon footprint of a UPS is made up of several factors. The largest is the battery, followed by removable UPS components (capacitors, fans, power electronics) and permanent components such as transformers. In order to drastically minimise the UPS footprint, Chloride is proposing the first low-carbon UPS solution that combines a best-in-class UPS system with an SMC battery, fully controlled and managed by the UPS.

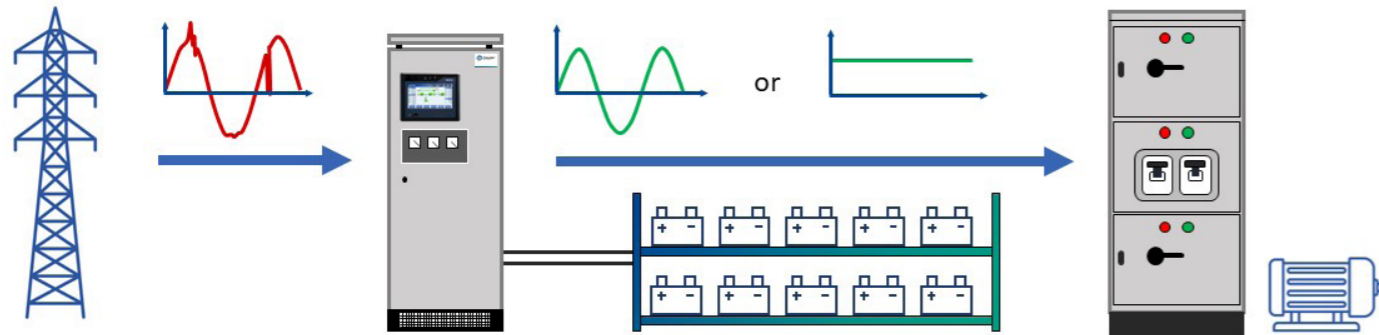

Schematic representation of UPS system and its role

Industrial Uninterruptible Power Supply systems (UPS) are designed for 100% reliability for the most demanding industrial environments that are characterized by wide operating temperature range, dust, aggressive atmosphere, remoteness, grid instability and other challenges. Its primary objective is to support the critical loads in case of grid power supply interruption that will protect people's safety and assets integrity.

UPS systems always include two main components: the power electronics cabinet that acts as a rectifier, charger or inverter and the battery that provides the autonomy required by the process. In terms of overhaul UPS system carbon footprint, battery plays an important role and should be considered in the global CAPEX/OPEX and carbon footprint of the site.

AC & DC Chloride® Industrial UPS



Specifically designed for industrial installations, we use proven technology with on-line double conversion thyristor/IGBT core. These systems have track record of over 30 years, allowing us to maximize reliability, availability and repairability as well as avoid new carbon emissions with end-of-life upgrades.



Chloride® Master Battery Control System (MBCS)



MBCS built in the UPS HMI allows monitoring and management of all connected SMC battery modules. As battery modules are connected in parallel it means that the system can automatically (hot swap) connect an N+1 battery element. This eliminates the need to multiply the number of elements by 2 for redundancy, optimising the system carbon footprint.



Battery SMC/Sodium Metal Chloride



Innovative battery technology based on sodium metal chloride chemistry and operating at high internal temperature avoids any gas emission. This battery has a proven track record in the field demonstrating high resistance to ambient temperatures, zero ageing and operating life of more than 25 years. No electrical live parts for a higher level of operator safety.

Carbon saving in comparison with traditional solution (UPS integrating VRLA or NiCd batteries)



Optimized for industrial applications, the latest generation of Chloride® UPS technology integrated with SMC Batteries (Sodium Metal Chloride) gives you a unique chance to reduce your carbon footprint and to protect your clean energy production with a low carbon UPS solution. A unique chance to reduce your carbon foot print & simultaneously save money by optimizing your OPEX/CAPEX and TCO.

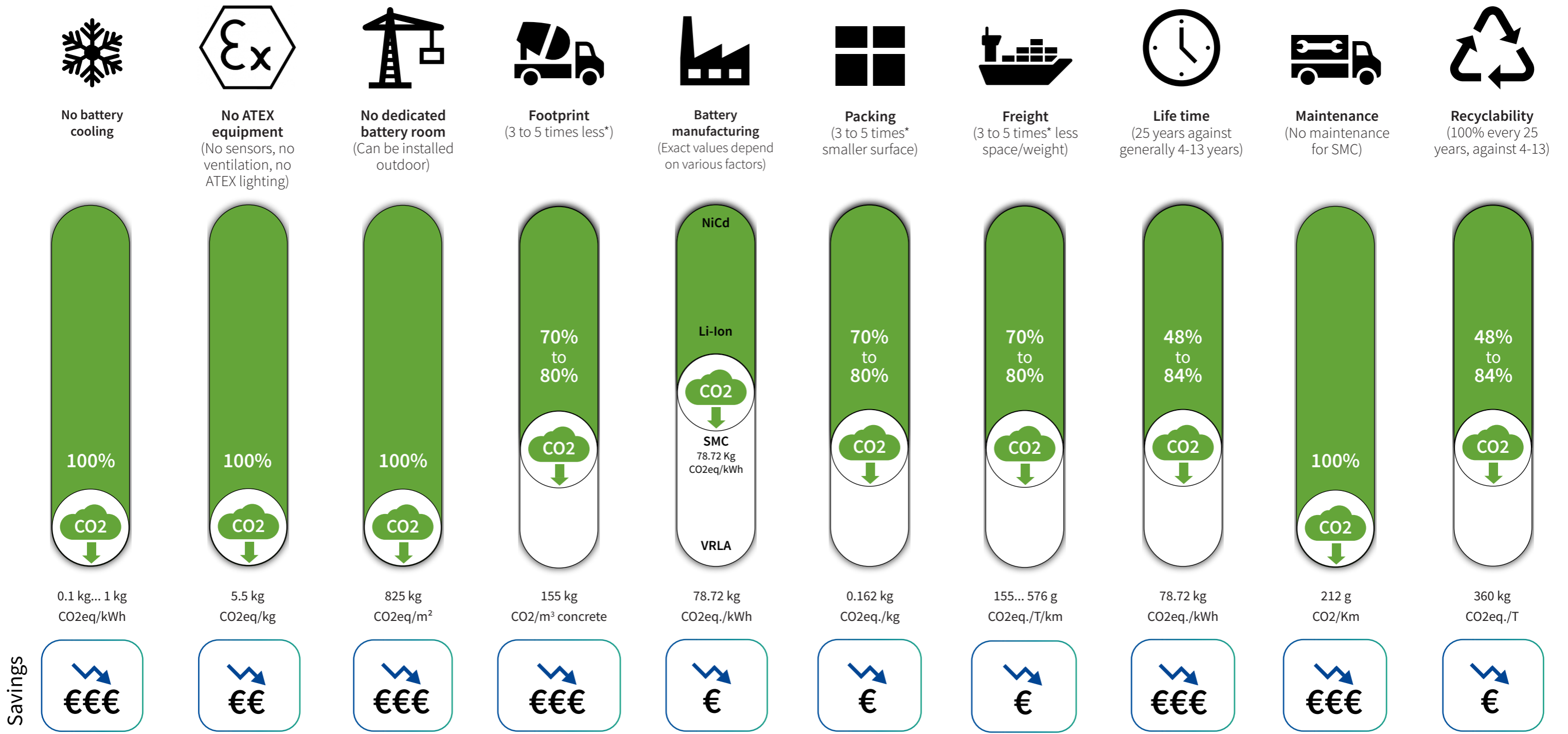

* 6 to 10 times less thanks to the Chloride® MCBS, where battery redundancy is needed

Disclaimer: Data provided for guidance purposes only and is not contractual and may vary according to the type of installation.



Source: 2023 Data Base Empreinte® ADEME energy transition agency
Battery SMC + BMS total consumption: 100W/battery should be considered

Chloride® selected products for H₂ installations



Low carbon solution

SMC Battery compatibility	N/A	No	Yes* <small>*exclud. FP40R</small>				No	
Master Battery Control	No	No	No	Yes	Yes	Yes	No	No

Output

Output Voltage	DC				AC		DC
Rating (Max)	7-80 Ah	4.5kW	66 kW	440 kW	80 kVA	500+ kVA	80 kVA
Output current (A)	<30 A	<180 A	<400 A	<2500 A	-	-	<500A
Battery voltage (Vdc)	12/24/48	12/24/48 110-127/220	24/48/110-127/220* <small>*exclud. FP50R</small>	24/48/110-127/220	110/220/400		110/125/220

Input

AC Input	1-ph AC		1-ph AC 3-ph AC		1-ph AC 3-ph AC	3-ph AC	3-ph AC	1-ph AC 3-ph AC
DC Input	No				Yes (CP70i)		No	

Mechanical

Integrated Battery	Yes	Yes	Integrated or External	External			
Footprint	Ultra compact		Compact		Optimized		Compact
Mounting	Wall-mount		Floor-stand				

Other features

Cooling	Natural	Forced or natural		Forced		Natural	
Technology	Switch mode	SCR (Thyristor)		Full IGBT (Low THDi)		SCR / IGBT	SCR / IGBT
Advantages	Standard product with limited number of options: effective lead time		Customized product with unlimited options (communication protocols, cable entry, analog meters, touch screen...)			Smallest IECEx UPS on the market (Patented innovation)	

More details: Refer to <https://www.chloride.com/products>

Services & Full scale Project Management capabilities

Chloride® Services

With a comprehensive service offering, Chloride® team supports entire critical infrastructure, improving electrical network availability and ensuring operator's peace of mind 24/7.

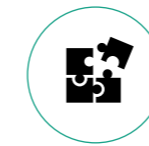

PARTS

Obsolescence management, Spare parts, Spares for stock



START-UP SERVICES

Warranty extension, Remote commissioning, Site operator training, Commissioning, Installation supervision



MAINTENANCE SERVICES

Refurbishment & upgrades, Remedial works, Preventive maintenance

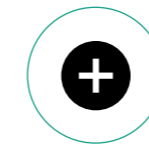

LIFE EXTENSION SERVICES

Life extension upgrade, Major system upgrade, SMC/Salt Batteries



CHLORIDE® EXPERT SERVICES

Advanced certified training, Condition monitoring & maintenance, Site expertise audits, Site surveys

Customer Project Schedule

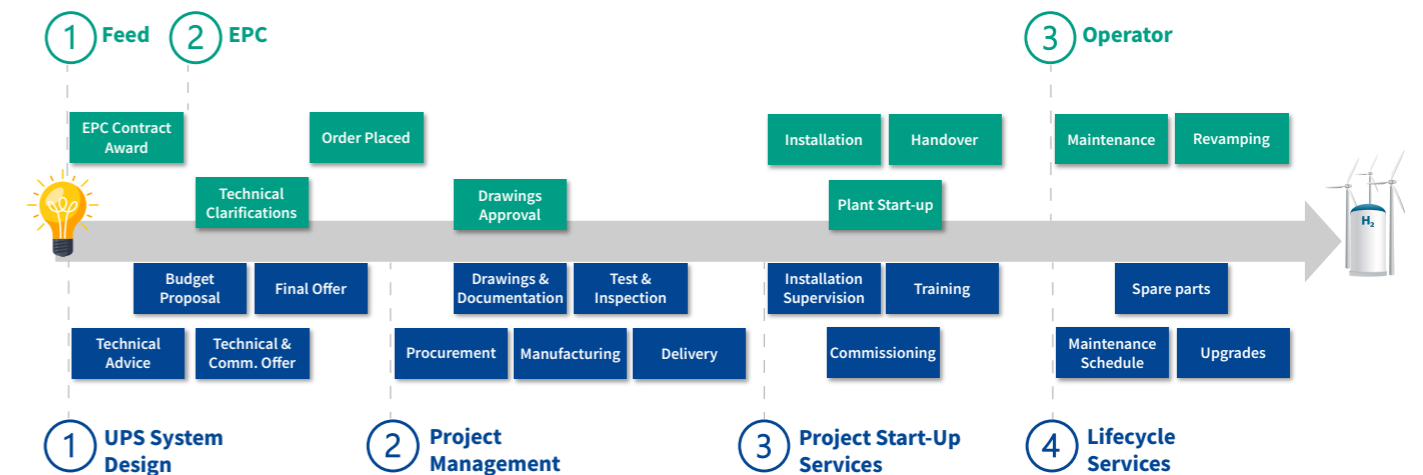

Chloride Project Schedule



Chloride™
Power to Protect

member of professional
organisations



Chloride.com | Global & Europe, Chloride SAS

30, Avenue Montgolfier - BP 90 - 69684 Chassieu - France

T: +33 (0)4 78 40 13 56

[Hello@Chloride.com](mailto>Hello@Chloride.com)

© 2023 Chloride SAS. All rights reserved. Chloride, the Chloride logo and Chloride are trademarks or registered trademarks of Chloride SAS. All other names and logos referred to are trade names, trademarks or registered trademarks of their respective owners. Whilst every precaution has been taken to ensure accuracy and completeness herein, Chloride SAS assumes no responsibility for, and disclaims all liability for, damages resulting from the use of this information or for any errors or omissions. Specifications are subject to change without notice.

Chloride®-Hydrogen-Solutions-BR-EN-gl-rev4-0825