

Chloride® CP Range

Customized to user specification
Full portfolio of industrial options



Benefits

Technical and budgetary optimization.

Battery can represent a significant part of UPS budget in greenfield or brownfield projects. That's why Chloride® CP70R is designed with a wide output DC voltage range to optimize:

- Number of battery cells
- Battery capacity and therefore the price, as per the required autonomy

Seamless integration with operating environment.

A made-to-order system can accommodate:

- Various solutions to operate with the differing input voltage networks (nominal value, tolerance, frequency)
- Generous internal space to adapt terminal block size to input and output cables.
- Dedicated fault and status loops for enhanced interfacing with existing DCS and SCADA systems.

Very high reliability. The unique design provides natural cooling of both thyristors and the enclosure on most ratings to:

Offer full power availability at the maximum design temperature.

- Enable high MTBF above 150 000 hours, with appropriate maintenance plan
- Eliminate the need to replace hard to reach internal fans on power bridges

Ruggedized solutions.

The system may be tailored to various environments, e.g. high temperatures, earthquakes or vibrations, dust, elevation, moisture.

The Chloride® CP70R industrial rectifier-battery charger is the flagship rectifier of the Chloride® range. It combines reliability from naturally cooled thyristor-based rectifier with proven digital control technology to offer the best performances in any electrical and environmental conditions.

Range Overview

Combined with an industrial stand-by battery, Chloride® CP70R rectifier-charger protects DC critical industrial equipment and processes from the damaging effects of power interruptions and losses. It features a microprocessor control which offers exceptional output stability and allows adaptability to various application requirements.

Chloride® CP70R range of rectifiers-chargers is available from 25 A to 250 A with single-phase input, and from 25 A to 2500 A with three-phase input. It offers several output voltages from 24 Vdc to 240 Vdc.

Chloride® CP70R is also available with 400 Vdc output. This configuration can be combined with a CP70i inverter to design specific high ratings double conversion AC UPS systems (up to 500 kVA).

To further improve load availability and process reliability, Chloride® CP70R is able to operate in dual or trial parallel configuration, with single or dual batteries, and can include a DC bus-tie.

Applications

- Power generation plants
- Transmission and Distribution substations
- Continuous process industries
- Oil & Gas and Petrochemical industries
- Rail transport



Example of Chloride® CP70R-48V-200A-6P

Key Features

- Continuous operation at full load at 104°F (40°C) ambient to meet industrial-level reliability requirements
- Resistance to vertical and horizontal acceleration up to 0.5 g using robust mechanical design
- Designed for 20+ years of continuous operation with appropriate maintenance plan
- Isolation transformer included
- Full compatibility with lead-acid and nickel-cadmium batteries, sealed or vented, Sodium Metal Chloride Batteries (SMC)

Technical Data

Input	
AC voltage	
• Single phase	1 x 220 V, 1 x 120 V ⁽¹⁾
• Three phase	3 x 480 V, 3 x 208 V, 3 x 400 V ⁽¹⁾
Voltage tolerance	+/- 10 %
Neutral configuration	Any configuration, with or without neutral
Frequency	60 Hz (50 Hz)
Frequency tolerance	+/- 5 %
Frequency range (temporary)	45 Hz to 65 Hz (with 50 Hz nominal)
Total harmonic current distortion (THDI)	< 34 % (6-pulse version) < 12 % (12-pulse version) ⁽²⁾
Inrush current	< 15 x In (for 6-pulse and 12-pulse)

Output	
Nominal DC voltage	24 V 48 V 110-127 V 220-240 V 400V
Output DC voltage range	17-40 V 36-75 V 88-160 V 176-300 V 296-550 V
Voltage stability (in stabilized floating mode, input within tolerance)	
• Unitary system	+/- 1 % ⁽³⁾
• Parallel systems	+/- 1 % to +/- 2 % ⁽³⁾
Voltage ripple	≤ 1 % RMS, in float mode, battery disconnected
Current limitation	I nominal

Battery	
Type	Lead acid or nickel cadmium, vented or recombination, SMC batteries
Autonomy	From few minutes to several hours, on request
Battery current limitation (typical, float & boost modes)	0.1 C (lead-acid battery) 0.2 C (nickel-cadmium battery)

General data	
Operating temperature	32 to 104 °F ⁽⁴⁾ / 0 to 40°C ⁽¹⁾
Storage temperature	-4 to 158 °F / -20 to +70 °C
Relative humidity	< 95 % non condensing
Operating altitude	3200 feet / 1 000 m max without derating ⁽¹⁾
Cooling	Natural convection on most of the range
Efficiency	Up to 96 % according to rating
External protection	NEMA 1 ⁽¹⁾ (IP 20 ⁽¹⁾) according to IEC 60529)
Internal protection	Protection against unintentional direct contacts, as per IEC 60950-1
Noise (at 1m in front of the unit)	55 – 65 dB according to rating
Cabinet color	Grey RAL 7032 ⁽¹⁾
Dimensions	Varying according to ratings & options

(1) Other value on request

(2) May vary between 10 and 14% according to operation conditions.
Option for THDI ≈ 5% (+/- 1pt) available on 12-pulse version

(3) May vary depending on DC output voltage and system configuration

(4) 6-pulse version only
5) 12-pulse version only

Ratings

Single phase input : Output current (A) vs Output voltage (Vdc)			
	24 Vdc	48 Vdc	110-127 Vdc
	25	25	25
	60	60	60
	100	100	100
	160	160	160
	250	250	250

Three phase input : Output current (A) vs Output voltage (Vdc)					
	24 Vdc	48 Vdc	110-127 Vdc	220-240 Vdc	400 Vdc
-	-	-	25 ⁽⁴⁾	25 ⁽⁴⁾	-
-	-	60 ⁽⁴⁾	50	50	-
100 ⁽⁴⁾	100 ⁽⁴⁾	100 ⁽⁴⁾	100 ⁽⁴⁾	100 ⁽⁴⁾	-
-	-	125 ⁽⁵⁾	125 ⁽⁵⁾	125	-
160 ⁽⁴⁾	160 ⁽⁴⁾	160 ⁽⁴⁾	160 ⁽⁴⁾	160 ⁽⁴⁾	-
200 ⁽⁵⁾	200 ⁽⁵⁾	200 ⁽⁵⁾	200 ⁽⁵⁾	200	-
250 ⁽⁴⁾	250 ⁽⁴⁾	250 ⁽⁴⁾	250 ⁽⁴⁾	250	-
320 ⁽⁵⁾	320 ⁽⁵⁾	320	320	320	-
400 ⁽⁴⁾	400 ⁽⁴⁾	400 ⁽⁴⁾	400 ⁽⁴⁾	400	400
500 ⁽⁵⁾	500	500	500	500	500
600 ⁽⁴⁾	600 ⁽⁴⁾	600	600	600	600
800	800	800	800	800	800
1000 ⁽⁴⁾	1000	1000	1000	1000	1000 ⁽⁵⁾
1200	1200	1200	1200	1200 ⁽⁵⁾	1200 ⁽⁵⁾
1500 ⁽⁴⁾	1600 ⁽⁵⁾	1600 ⁽⁵⁾	1600 ⁽⁵⁾	1600 ⁽⁵⁾	1600 ⁽⁵⁾
2000 ⁽⁴⁾	2000 ⁽⁵⁾	2000 ⁽⁵⁾	2000 ⁽⁵⁾	2000 ⁽⁵⁾	-
2500 ⁽⁴⁾	2400 ⁽⁵⁾	2400 ⁽⁵⁾	-	-	-

Standards

Standards	
UL 1012 210	Standard for Power Units Other Than Class 2
NEMA PE5 - 1997 (R2003)	Utility type battery chargers

Options

Consult us for any other requirements, subject to feasibility

Rectifier	<ul style="list-style-type: none"> • 12-pulse rectifier • Harmonic filter on 12P for THDi ≈5 % (+/- 1pt) • Voltage ripple filter (psophometric for 48 Vdc output only) • Blocking diode • Other input voltage (1 x 110 to 3 x 690 VAC) • Inrush current limitation to 5 x In • Surge and/or lightning protections
Battery	<ul style="list-style-type: none"> • Battery circuit protection box • Battery reversed polarity detection • Battery low-voltage disconnection contactor (LVD) • DC earth fault detection • Battery room temperature sensor • Battery monitoring system (Chloride® BMS) • Battery cabinet / rack
System	<ul style="list-style-type: none"> • Operation in ambient temperature up to 131°F (55°C) • Parallel configurations (dual, tri) • Hot stand-by configuration • Input/output isolators • Dropping diodes / DC/DC serial regulator • Isolated DC/DC converter • DC distribution • Earth fault detection or monitoring • Internal cabinet lighting • Anti-condensation heater • Cabinet temperature monitor
Mechanical	<ul style="list-style-type: none"> • External ingress protection NEMA 2 • Top cable entry • Specified color of panels • Special feet height (7.9 inches or 11.8 inches) • Special keylock • Non-magnetic gland plate (brass or aluminum) • Lifting eyes • 12 Gauge side panels thickness • Specified cabinet identification (tag, nameplate) • Anti-seismic design
Communication	<ul style="list-style-type: none"> • Touch pad Human-Machine Interface • Front panel analogue meters (2.8 x 2.8 inches, class 1.5 or class 1) • Transducers 4-20mA • Additional volt-free contacts • Modbus RTU (RS232 or RS485) • Modbus / TCP • Profibus • IEC61850 protocol • PPVis monitoring software • PPVis2 monitoring software with touchpad display • Mimic panel: <ul style="list-style-type: none"> - Passive mimic of the system - Active mimic with integrated LEDs • Lamp indicator on front panel (0.9 inches diameter)

Internal layout examples

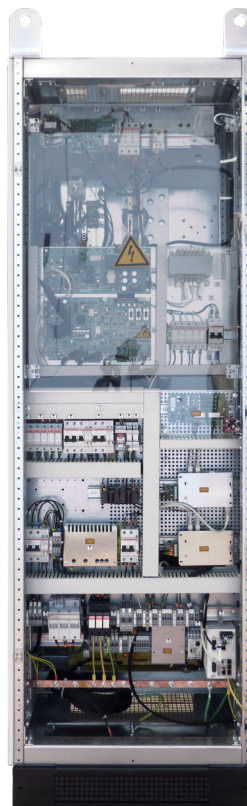

Example of Chloride® CP70R-110V-50A-6P



Example of Chloride® CP70R-127V-150A-6P

The above illustrations show some examples of finished systems. As each system is customized to specification, the internal layout might be different for different units.

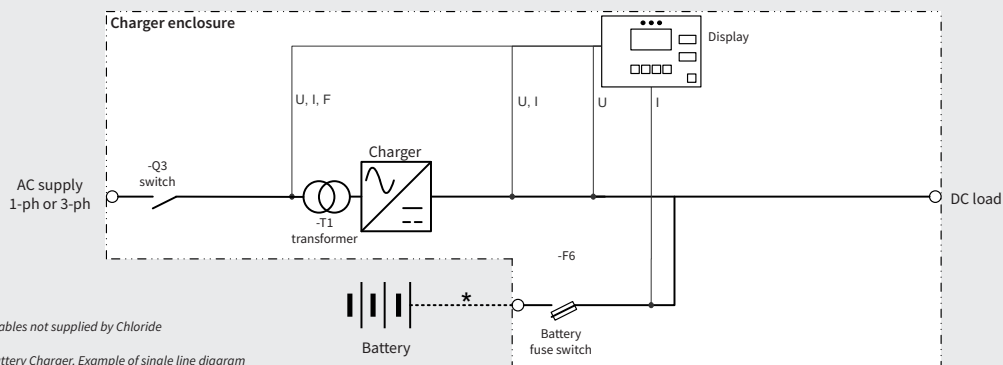

LYNX by Chloride® (HMI) - Optional

As an option, the front panel of the system includes a large, colour touchscreen LYNX with intuitive graphical interface that simplifies system setup, operation, and troubleshooting.



LYNX by Chloride® - Human-machine Interface (HMI)

System Set-up

- Selection of the language
- Set-up of the date and time
- Adjustment of the brightness
- Configuration of the main screen: the user can choose between displaying the block diagram only or the block diagram with the input and/or output measurements
- Configuration of the Modbus (optional)
- Adjustment of system parameters in a password protected area (e.g. battery voltage level, number of cells)

System Operation

- View of the single line diagram with color-coded blocks and power flow
- Check the position of the system main isolators (open/close status)
- Access to blocks information and measurements via a simple touch
- Change of the battery charging mode (float, boost, initial charge)
- Launch of a battery test

System troubleshooting

- Color-coding of each block for immediate identification of possible alarm
- Memorization of some critical fault messages with a mandatory fault acknowledgement
- Checking of all the triggered status, warning and fault messages with detailed description via a simple touch
- Event logger that records up to 2000 events with date and time stamp
- Export of all the recorded events using USB flash drive. The extracted HTML file allows root cause analysis.



With complete service portfolio and extensive field service network, we ensure system lifelong reliability.

- Project services and commissioning
- Maintenance services and plans
- Performance improvement and upgrades

At Chloride we design, manufacture and service custom-made Uninterruptible Power Systems to protect your mission-critical industrial applications.